

17x2 UNDER FLOOR UNION FOR PIPE CONNECTION

KAS®



TECHNICAL DATA SHEET

Product Name

Under Floor Union for Pipe Connection

Intended Use

Installation Systems

DIMENSIONS

Code	06.01.317
D1(thread)	1/2"
D2(thread)	M23X1,5
AA1	25
AA2	26
L1	16
L2	38,5

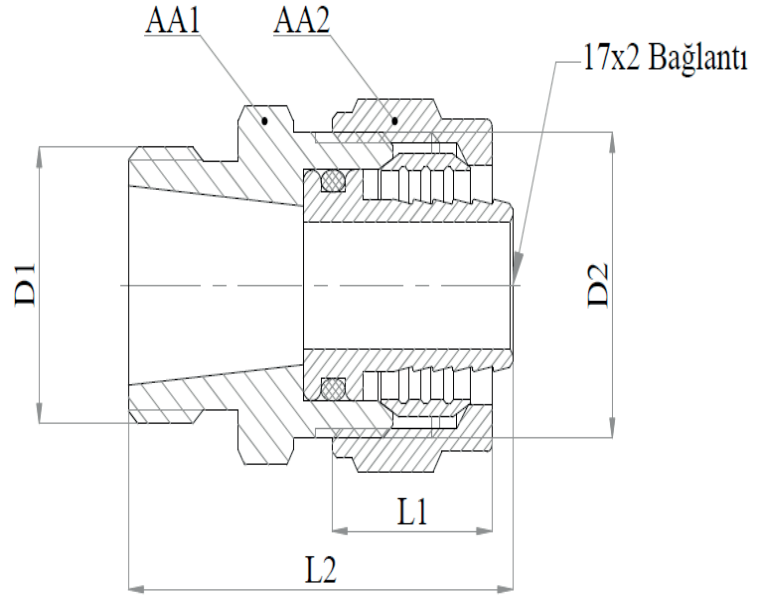

MATERIAL PROPERTIES

BODY	BRASS (CW617N)/(CW614N)
NUT	BRASS (CW617N)/(CW614N)
RING	BRASS (CW617N)/(CW614N)
TIP	BRASS (CW617N)/(CW614N)
TIP-ORING	NBR

SURFACE PROPERTIES

TIP	NICKEL
NUT	NICKEL



17x2 UNDER FLOOR UNION FOR PIPE CONNECTION



KAS[®]

INSTALLATION and OPERATING INSTRUCTION

- 1-** Do not unpack the valve until installation to prevent falling of any unwanted substance that may affect the working of valve.
- 2-** Take measures against any possible damage that may occur during transport and shipment.
- 3-** Clean away every unwanted substance in your system before installation.
- 4-** Valve should be off position while installing.
- 5-** Be careful that the thread length of the part that will be installed to the valve will not be too longer or too shorter than the thread length of the valve.
- 6-** While installing, grab the valve by the appropriate tool from the across flats where you'll install it.
- 7-** During installation do not use excessive adhesive or any unsuitable substance.
- 8-** Use the valve fully open or fully closed position.
- 9-** Do not paint the valve. Do not expose the valve with abrasive chemicals.
- 10-** Do not use any other tools for opening or closing the valve and do not remove the handle.
- 11-** In case of any damage or disorder, valve should be changed by authorities.
- 12-** Complying with the installation and usage instruction is compulsory. Otherwise, the product will be cut of guarantee.
- 13-** Do not forget to get the document of guarantee. This document is valid only with the related bill.